

## Edelstahlkugelhahn, 3-teilig, metallisch dichtend Stainless steel ball valve, 3-pc., metal seated Typ PA-812D.766.M / PA-813D.766.M

### Technische Daten

#### Bauform

Voller Durchgang  
 3-teilig  
 Gehäuse: 1.4408  
 Kugel: 1.4408 hartverchromt  
 Dichtung: AISI 316 stellitiert  
 mit ISO-Direktaufbauflansch

### Specification

#### Design

Full port  
 3-pc.  
 Body: 1.4408  
 Ball: 1.4408 hard chromed  
 Seat: AISI 316 stellite  
 with ISO-Directmountingpad

#### Betriebsdruck

PN 135

#### Pressure Range

PN 135

#### Anschluss

PA-812D.766.M: mit Anschweißenden  
 PA-813D.766.M: mit Gewindeenden

#### Connection

PA-812D.766.M: with butt weld ends  
 PA-813D.766.M: with threaded ends

#### Betriebstemperatur

max. 425°C

#### Temperature Range

max. 425°C

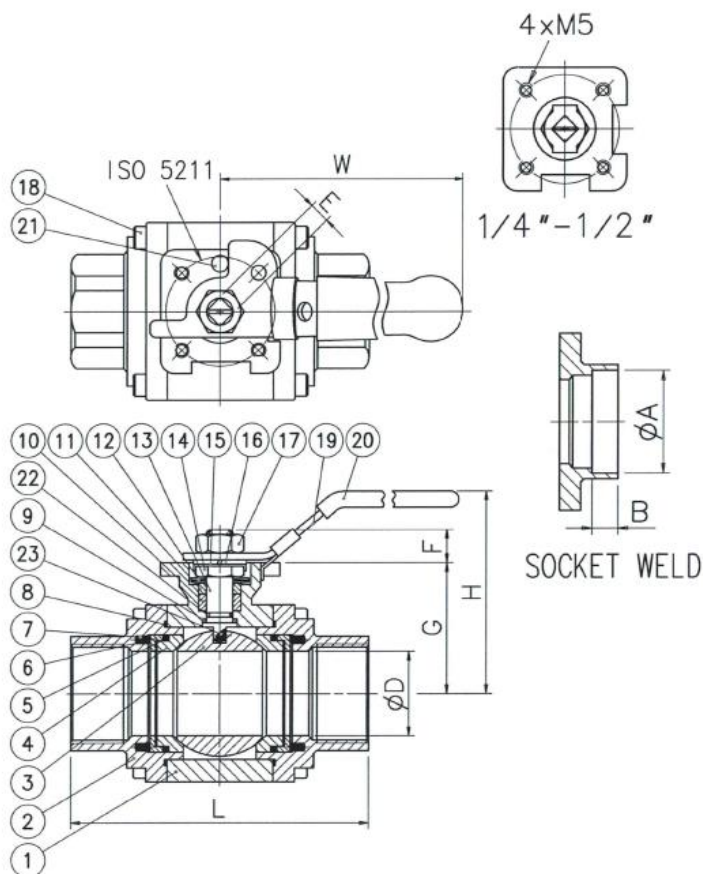

Größe 1/4" bis 2"

NO.	Part Name	Materials
1	Body	ASTM A351 CF8M
2	Body Cap	ASTM A351 CF8M
3	Ball	ASTM A276 316
4	Seat	ASTM A276 316
5	Seat Gasket	Graphite
6	Seat Packing	AISI 304
7	Seat Ring	JIS G3565 SWOCV-V ASTM A276 304 ASTM B637 Inconel X-750
8-1	Body Gasket	Graphite
8-2		PTFE
9-1	Thrust Washer	Graphite
9-2		PTFE
10	Stem Packing	Graphite
11	Gland	AISI 304
12	Belleville Washer	DIN 17221 500CrV4
13	Stem	ASTM A276 316 ASTM A564 17-4PH
14	Gland Nut	AISI 304
15	Lock Clip	AISI 304
16	Spring Washer	AISI 304
17	Handle Nut	AISI 304
18	Body Bolt	ASTM A193 B8
19	Handle	AISI 304
20	Sleeve	Vinil Plastisol
21	Stop Pin	AISI 304
22	Stem O-Ring	Viton
23	Anti-Static Device	AISI 316

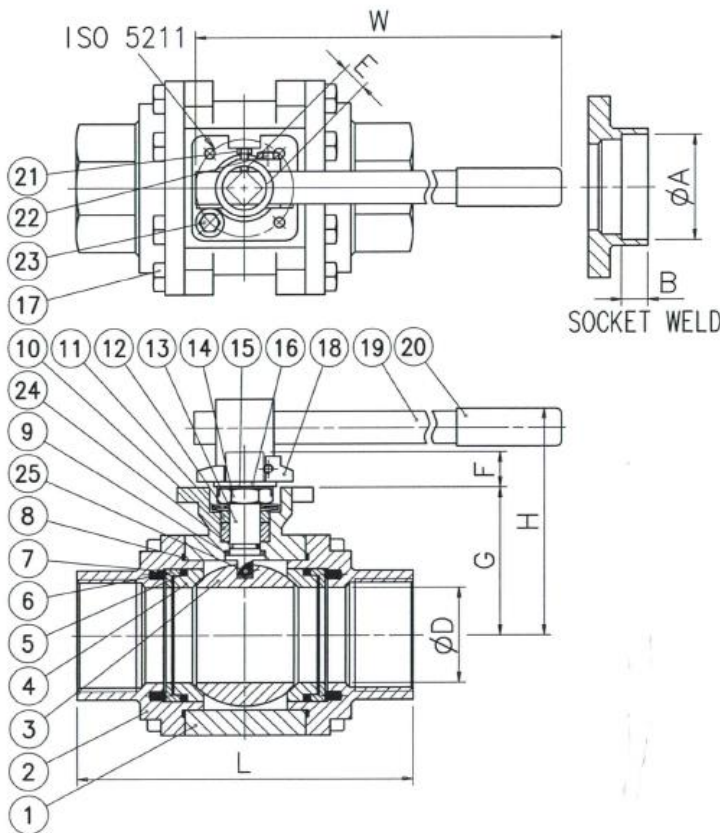

Größe 2 1/2" bis 4"

NO.	Part Name	Materials
1	Body	ASTM A351 CF8M
2	Body Cap	ASTM A351 CF8M
3	Ball	ASTM A276 316
4	Seat	ASTM A276 316
5	Seat Gasket	Graphite
6	Seat Packing	AISI 304
7	Seat Ring	JIS G3565 SWOCV-V ASTM A276 304 ASTM B637 Inconel X-750
8-1	Body Gasket	Graphite
8-2		PTFE
9-1	Thrust Washer	Graphite
9-2		PTFE
10	Stem Packing	Graphite
11	Gland	AISI 304
12	Belleville Washer	DIN 17221 500CrV4
13	Stem	ASTM A276 316 ASTM A564 17-4PH
14	Gland Nut	AISI 304
15	Lock Clip	AISI 304
16	Spring Washer	AISI 304
17	Body Bolt	ASTM A193 B8
18	Handle	ASTM A351 CF8
19	Speel Pipe	AISI 304
20	Sleeve	Vinyl Plastisol
21	Hex Cap Screws	AISI 304
22	Hex Cap Screws	AISI304
23	Stop Pin	AISI 304
24	Stem O-Ring	Viton
25	Anti-Static Device	AISI 316

NPS	DN	ØD	L	E	F	G	H	W	ØA	B	ISO 5211		
1/4"	8	11	125	9	8	37,5	70	140	14,2	10	F04		
3/8"	10								17,6				
1/2"	15	14	11	11	50	90	180	21,8	13				
3/4"	20	20,5	135	11	11	72	112	215	27,2	15	F04 – F05		
1"	25	25	150						60			100	33,9
1 1/4"	32	31,5	170	14	16	76	115	460	42,7	16		F07	
1 1/2"	40	37	165						93		133		61,2
2"	50	50	190						22		24		116,5
2 1/2"	65	65	220	127	184	89,8							
3"	80	80	250	27	29	159	242	600		115,2		20	
4"	100	100	280										