

## 3-Wege Muffenkugelhahn, Messing/ 3-way ball valve, brass PA-182.388.P

| Technische Daten          | Specification            |
|---------------------------|--------------------------|
| <b>Bauform</b>            | <b>Design</b>            |
| Reduzierter Durchgang     | Reduced Port             |
| <b>Anschluss</b>          | <b>Connection</b>        |
| Beidseitig Innengewinde   | Female threads           |
| ¼" - 2"                   | ¼" - 2"                  |
| L - oder T - Bohrung      | L - or T - bore          |
| <b>Betriebsdruck</b>      | <b>Pressure Range</b>    |
| PN 25 - 32                | PN 25 - 32               |
| <b>Betriebstemperatur</b> | <b>Temperature Range</b> |
| min. - 20°C - max. 150°C  | min. - 20°C - max. 150°C |

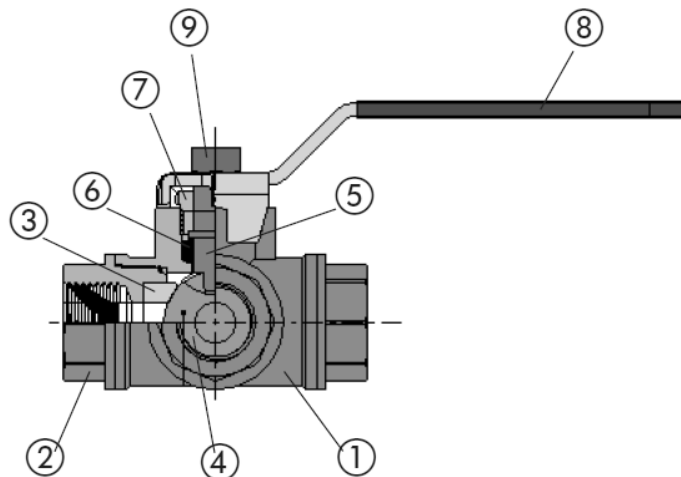

| N. | PART NAME   | MATERIAL                             | TREATMENT      |
|----|-------------|--------------------------------------|----------------|
| 1  | Body        | Brass -<br>CW 617N - UNI EN 12165/98 | Nickel plated  |
| 2  | Body end    | Brass -<br>CW 617N - UNI EN 12165/98 | Nickel plated  |
| 3  | Seat        | PTFE                                 |                |
| 4  | Ball        | Brass -<br>CW 617N - UNI EN 12165/98 | Chrome plated  |
| 5  | Stem        | Brass<br>CW 614N - UNI EN 12164/98   |                |
| 6  | Stem seat   | PTFE                                 |                |
| 7  | Packing nut | Brass -<br>CW 614N - UNI EN 12164/98 |                |
| 8  | Handle      | Steel                                | Plastic coated |
| 9  | Nut         | Steel                                | Zinc plated    |

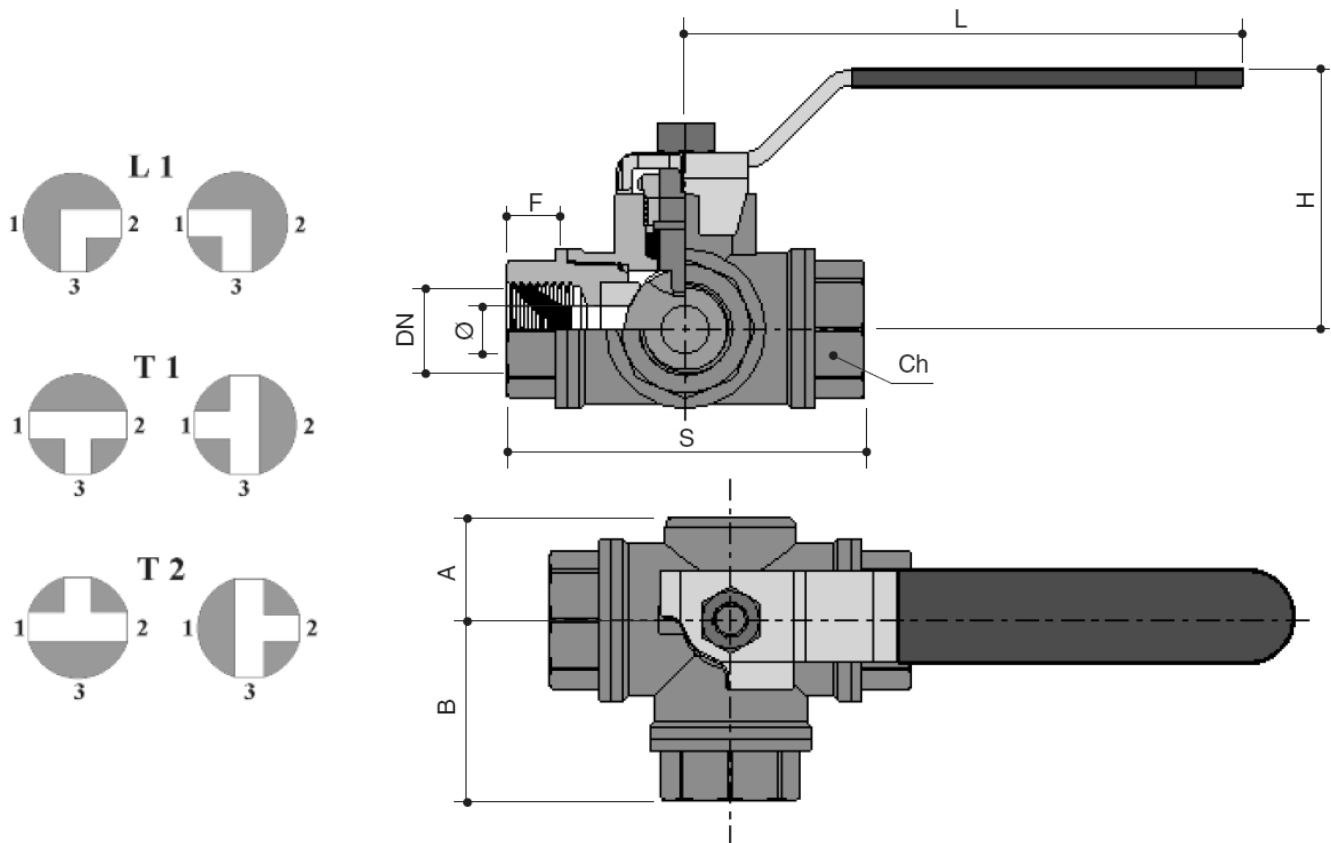

| DN | ¼" | 3/8" | ½"  | ¾"  | 1"  | 1 ¼" | 1 ½" | 2"  |
|----|----|------|-----|-----|-----|------|------|-----|
| Ø  | 10 | 10   | 12  | 15  | 20  | 25   | 32   | 40  |
| F  | 12 | 12   | 14  | 16  | 19  | 21   | 23   | 26  |
| S  | 74 | 74   | 80  | 90  | 105 | 115  | 138  | 161 |
| H  | 58 | 58   | 60  | 64  | 73  | 79   | 100  | 105 |
| L  | 90 | 90   | 125 | 125 | 140 | 140  | 220  | 220 |
| A  | 22 | 22   | 24  | 28  | 31  | 35   | 42   | 48  |
| B  | 37 | 37   | 39  | 46  | 52  | 58   | 69   | 80  |
| Ch | 22 | 22   | 29  | 34  | 42  | 50   | 57   | 68  |

| KW FACTOR |    |
|-----------|----|
| ¼" - 10   | 3  |
| 3/8" - 10 | 3  |
| ½" - 12   | 4  |
| ¾" - 15   | 6  |
| 1" - 20   | 12 |
| 1 ¼" - 25 | 21 |
| 1 ½" - 32 | 35 |
| 2" - 40   | 47 |