

## Doppelt-exzentrische Absperrklappe mit Zentrieraugen, metallisch dichtend/ *Double eccentric butterfly valve, wafer type, metal seated*

**PA-930.235.M / 930.266.M**

<b>Technische Daten</b>	<b>Specification</b>
<b>Bauform</b>	<b>Design</b>
Mit 2 Zentrieraugen	<i>With 2 holes</i>
Ab DN 350 mit 4 Gewindeaugen	<i>From DN 350 with 4 threaded holes</i>
Baulänge nach EN 558-1 (K-1)	<i>Face to face according to EN 558-1 (K1)</i>
Mit Handhebel	<i>With handlever</i>
Topflansch nach ISO 5211	<i>Topflange according to ISO 5211</i>
Ab DN 200 mit Schneckenradgetriebe und Handrad	<i>From DN 200 with gearbox and handwheel</i>
<b>PA-930.235.M</b>	<b>PA-930.235.M</b>
Gehäuse: Stahl WCB	<i>Body: WCB</i>
Scheibe: CF8	<i>Disc: CF8</i>
Dichtung: PTFE + 15% Graphit	<i>Seat: PTFE + 15% graphite</i>
<b>PA-930.266.M</b>	<b>PA-930.266.M</b>
Gehäuse: Edelstahl CF8M	<i>Body: CF8M</i>
Scheibe: CF8M	<i>Disc: CF8M</i>
Dichtung: PTFE + 15% Graphit	<i>Seat: PTFE + 15% graphite</i>
<b>Anschluss</b>	<b>Connection</b>
Passend zwischen Flansche PN 10/16 (Ab DN 350: PN 10 oder 16)	<i>Suitable between flanges PN 10/16 (from DN 350: PN 10 or 16)</i>
<b>Betriebstemperatur</b>	<b>Temperature Range</b>
Max. 350°C	<i>Max. 350°C</i>

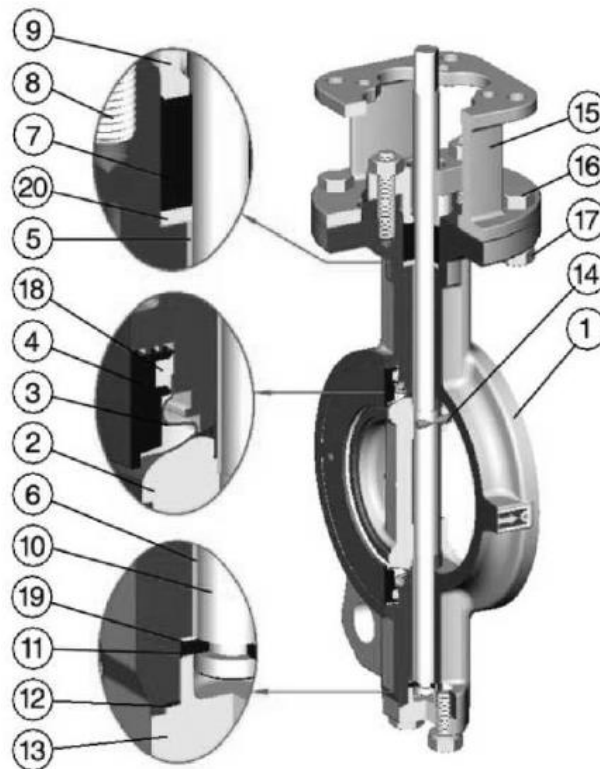



No.	Name	Materials	Specification		Remark
			JIS	ASTM	
1	BODY	CARBON STEEL	SC480	A216 Gr. WCB	
		STAINLESS STEEL	SCS 13A SCS 14A SCS 16A	A351 Gr. CF8 A351 Gr. CF8M A351 Gr. CF3M	
2	DISC	STAINLESS STEEL	SCS 13A SCS 14A SCS 16A	A351 Gr. CF8 A351 Gr. CF8M A351 Gr. CF3M	Disc edge equipped with hard chrome plated
3	METAL SEAT	STAINLESS STEEL	SUS 316	A240 Gr. 316	Nitrided
4	RETAINER	STAINLESS STEEL	SCS 13A	A351 Gr. CF8	
			SCS 14A	A351 Gr. CF8M	
			SCS 16A	A351 Gr. CF3M	
5	BUSHING	STAINLESS STEEL	SUS 316	A182 Gr. F316	Nitrided
6	BUSHING	STAINLESS STEEL	SUS 316	A182 Gr. F316	Nitrided
7	GLAND PACKING	GRAPHITE			
8	STUD	STAINLESS STEEL	SUS 304	A193 Gr. B8	
9	GLAND	STAINLESS STEEL	SCS 13A	A351 Gr. CF8	
			SCS 14A	A351 Gr. CF8M	
			SUS 410	A182 Gr. F6a	
			SUS 304	A182 Gr. F304	
			SUS 316	A182 Gr. F316	
			SUS 630 XM-19	A564 Gr. 630 A479 Gr. XM-19	
11	THRUST RING	STAINLESS STEEL	SUS 316	A240 Gr. 316	
12	SEAL	GRAPHITE			
13	BOTTOM COVER	STAINLESS STEEL	SCS 13A	A351 Gr. CF8	
			SCS 14A	A351 Gr. CF8M	
			SCS 16A	A351 Gr. CF3M	
14	PIN	CARBON STEEL	SC480	A216 Gr. WCB	
		STAINLESS STEEL	SUS 316	A182 Gr. F316	
15	YOKE	DUCTILE IRON	FCD 450	A536 Gr. 65-45-12	For 24" valve only
		CARBON STEEL	SC480	A216 Gr. WCB	Regular
16	BOLT	STAINLESS STEEL	SUS 304	A351 Gr. CF8	Option
17	NUT	STAINLESS STEEL	SUS 304	A193 Gr. B8	
18	GASKET	GRAPHITE		A194 Gr. 8	
19	WASHER	STAINLESS STEEL	SUS 316	A240 Gr. 316	
20	WASHER	STAINLESS STEEL	SUS 316	A240 Gr. 316	

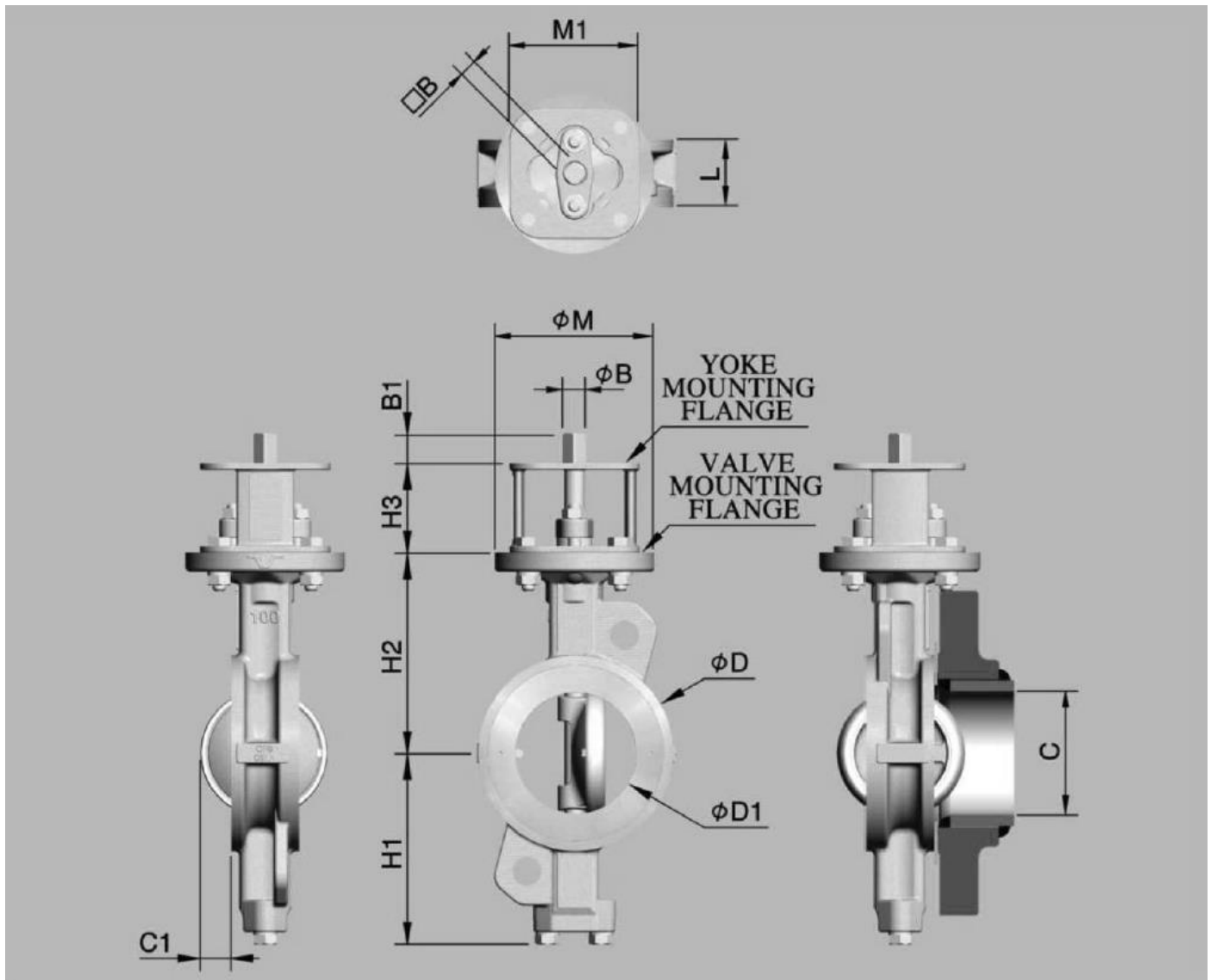

Size mm	Face to Face L	Dimensions							Mounting flange (ISO 5211)				Shaft end			Suitable pipe flange ★	Weight kg	
		H1	H2	H3	$\phi D$	$\phi D1$	C	C1	Valve Type	$\phi M$	Yoke Type	M1	$\phi B$	$\square B$	B1			
50	43	99	118	60	92	37	49.5	2	F07	90	F07	F05	70	14	11	18	ACDEFKMN	3.9
65	46	110	125	60	108	63	62.3	15	F07	90	F07	F05	70	14	11	18	ABCDEFGHIKMN	4.5
80	47	128	140	70	126	78	65.9	22	F10	125	F10	F07	102	18	14	23	ABCDEFGHIKMN	7
100	53	150	157	70	153	95	93	25	F10	125	F10	F07	102	18	14	23	ABCDEFGHIKMN	9
125	57	163	170	70	184	118	120	36	F10	125	F10	F07	102	22	17	23	ABCDEFGHIKMN	12
150	56	176	185	70	212	143	149	50	F10	125	F10	F07	102	22	17	23	ACDEFKMN	13.5
200	62	206	220	80	268	188	196	70	F12	150	F12	F10	125	25	19	28	ACDEFKMN	22
250	68	238	260	80	326	236	243	90	F12	150	F12	F10	125	28	22	28	ACDEFKMN	32
300	78	269	290	100	375	282	289	106	F14	175	F14	F12	160	35	27	37	ACDEFKMN	48
350	78/92	306	326	100	416	322	329	125	F14	175	F14	F12	160	36	27	37	ACDEFKMN	66
400	102	342	370	120	476	371	377	140	F16	210	F16	F14	195	48	36	47	ACDEFKMN	107
450	114	370	395	120	534	418	423	157	F16	210	F16	F14	195	48	36	47	ACDEFKMN	130
500	127	399	430	120	588	466	471	177	F16	210	F16	F14	195	60	46	56	ACDEFKMN	163
600	154	455	490	150	692	570	572	210	F25	300	F16	-	300	60	46	56	ACDEFKMN	278
600	154	455	490	150	692	570	572	210	F25	300	F25	-	300	60	46	56	ACDEFKMN	278

★ A: 150LB B: 300LB C: PN10 D:PN16 E: PN20 F: PN25 G: PN40 H: PN50 K: 10K  
 ★ M: 16K N: B.S. 10 TABLE E P: 20K

Pipe limit size > C

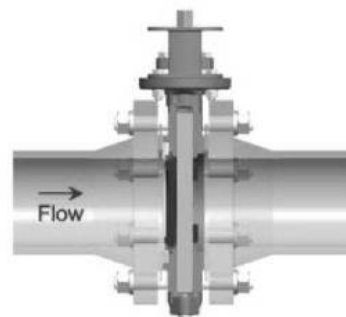
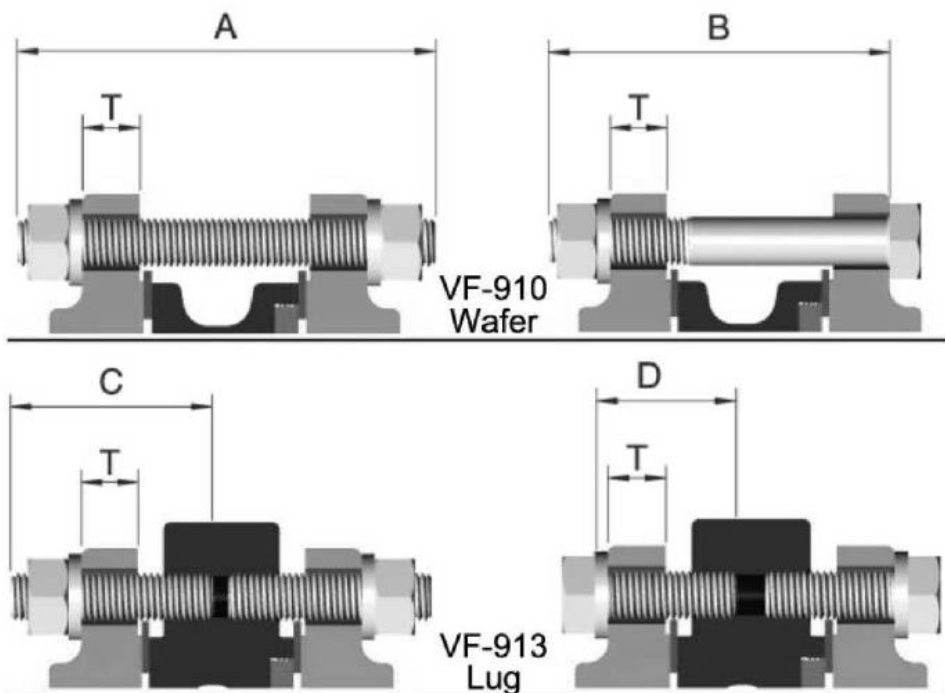

The seals flow can be executed in both directions. The following advantages can be assured while the suggested flow directions is used.

- Minimal start-up torque.
- Reduced seat wear.
- No direct contact between the fluid and the seat.

Size		PN10					PN16					PN20					PN25								
mm	inch	Bolt Size	A	B	C	D	T	Bolt Size	A	B	C	D	T	Bolt Size	A	B	C	D	T	Bolt Size	A	B	C	D	T
50	2	M16	130	120	65	45	20	M16	130	120	65	45	20	M16	135	125	70	50	22.5	M16	135	125	70	50	22
65	2.5	M16	130	120	65	45	20	M16	130	120	65	45	20	M16	135	125	70	50	23	M16	135	125	70	50	22
80	3	M16	135	120	65	45	20	M16	135	120	65	45	20	M16	140	130	70	50	24	M16	140	130	70	50	24
100	4	M16	145	130	70	50	22	M16	145	130	70	50	22	M16	145	135	75	55	24	M20	155	140	80	55	24
125	5	M16	145	135	75	50	22	M16	145	135	75	50	22	M20	155	140	75	55	24	M24	175	155	85	60	26
150	6	M20	160	140	80	55	24	M20	160	140	80	55	24	M20	160	145	80	55	26	M24	175	155	90	60	28
200	8	M20	160	145	80	55	24	M20	160	145	80	55	24	M20	170	155	85	60	29	M24	185	165	90	65	30
250	10	M20	175	160	85	60	26	M24	185	165	85	60	26	M24	195	175	95	70	31	M27	200	180	100	70	32
300	12	M20	185	170	90	65	26	M24	200	180	90	70	28	M24	205	185	105	70	32	M27	215	195	110	75	34
350	14	M20	185	170	90	65	26	M24	200	185	90	70	30	M27	220	195	105	75	35	M30	230	205	115	80	38
400	16	M24	220	200	110	70	26	M27	235	215	110	80	32	M27	245	225	125	85	37	M33	265	240	130	95	40
450	18	M24	235	215	115	75	28	M27	265	240	115	90	40	M30	270	240	130	95	40	M33	290	265	145	105	48
500	20	M24	245	230	125	75	28	M30	295	270	125	100	44	M30	290	265	140	95	43	M33	305	280	155	105	48
600	24	M27	290	270	145	85	34	M33	345	320	145	110	54	M33	335	310	165	105	48	M36	360	330	180	120	58

Size		ANSI B16.5 150LB					JIS10K					JIS 16K & 20K					B.S. 10 TABLE E								
mm	inch	Bolt Size	A	B	C	D	T	Bolt Size	A	B	C	D	T	Bolt Size	A	B	C	D	T	Bolt Size	A	B	C	D	T
50	2	5/8"	135	125	70	50	20	M16	130	115	65	45	16	M16	130	115	65	45	16	5/8"	120	110	60	40	10
65	2.5	5/8"	135	125	70	50	22	M16	130	115	65	45	18	M16	130	115	65	45	18	5/8"	120	110	60	40	14
80	3	5/8"	140	130	70	50	24	M16	130	115	65	45	18	M20	140	125	70	50	20	5/8"	120	110	60	40	14
100	4	5/8"	145	135	75	55	24	M16	135	120	70	50	18	M20	150	135	75	55	22	5/8"	135	120	65	45	17
125	5	3/4"	160	145	80	55	24	M20	150	135	75	55	20	M22	160	140	80	55	22	5/8"	140	125	70	50	17
150	6	3/4"	160	145	80	55	25	M20	155	140	80	55	22	M22	160	145	80	55	24	3/4"	145	130	70	50	17
200	8	3/4"	170	155	85	60	28	M20	160	140	80	55	22	M22	170	150	85	60	26	3/4"	152	135	75	50	19
250	10	7/8"	185	170	95	65	30	M22	175	155	85	60	24	M24	190	170	95	65	28	3/4"	165	150	85	55	22
300	12	7/8"	200	180	100	70	32	M22	185	165	90	60	24	M24	200	185	100	70	30	7/8"	185	170	95	65	25
350	14	1"	215	195	105	75	35	M22	190	170	95	65	26	M30	220	200	110	80	34	7/8"	195	175	95	70	29
400	16	1"	240	220	120	80	37	M24	220	205	110	70	28	M30	255	230	130	85	38	7/8"	225	205	110	75	32
450	18	1 1/8"	265	240	130	90	40	M24	240	220	120	75	30	M30	270	245	135	90	40	7/8"	240	225	120	80	35
500	20	1 1/8"	285	260	140	90	43	M24	250	230	125	75	30	M30	290	265	145	95	42	7/8"	260	245	130	80	38
600	24	1 1/4"	330	305	165	100	48	M30	295	270	145	85	32	M36	335	310	170	105	46	1 1/8"	325	300	165	100	48